

# TRP-C51

## User's Manual

Bluetooth To RS232/422/485 Converter



## User Manual

Printed DEC. 2007 Rev 1.0

### Copyright

Copyright Notice: The information in this manual is subject to change without prior notice in order to improve reliability, design and function and does not represent a commitment on the part of the manufacturer. No part of this manual may be reproduced, copied, or transmitted in any form without the prior written permission of manufacturer. Acknowledgment Products mentioned in this manual are mentioned for identification purpose only. Products names appearing in this manual may or may not be registered trademarks or copyright of their respective companies.

# 1.Introduction

Based on Bluetooth technology TRP-C51 allows you to wirelessly connect your RS232/422/485 devices to systems within the range over to 100M, TRP-C51 features wide range power input, auto RS232/422/485 signal switching and internal surge protection on RS422/485 lines. It also supports all common data format and baud rate which can be configured by the bundled TRP-BT utility from Windows system. TRP-C51 can operate in "direct link mode" and "paired mode" When in paired mode, the user just need to power two devices, and they will automatically connect without software and hardware changes on your systems that will replace your serial wire with a completed transparent wireless connection. It can be used for wide range of applications for wireless operation and monitoring process.

## 1-1.Features

- Bluetooth V1.2 Class 1 compliance. (2.5mW/4dBm)
- Transmission range over to 100M.
- Auto directionally RS485 signal communication.
- Support all common baud rate from 1.2K to 256Kbps.
- Comfortable TRP-BT configuration software (Windows version)
- RS232/422 and RS485 signal auto switching.
- Master/Slave connection mode selectable by software.
- LED indicators for Power/Link/TX/RX.
- Surge protection on RS422/RS485.
- Power supply: Screw terminal, or external DC adapter.
- Wide input range power supply.
- DIN rail and panel mount support.

## 1.-2.Specifications

- Power requirement: DC voltage input from +10V to +30V.
- RS232 signal: TXD, RXD, GND, RTS, CTS.
- RS422/485 connection: industrial plug-in screw terminal.
- RS485 signal: differential 2 half-duplex wires. (D+, D-)
- RS422 signal: differential 4 full-duplex wires.(TX+, TX-, RX+, RX-)
- Baud rate: 1.2Kbps to 256Kbps.
- Data bit 5,6,7,8.
- Support Parity check: None, Even, Odd.
- Stop bit: 1, 2.
- RS232 flow control RTS/CTS: Enable, Disable.
- Host PC com port to TRP-C51 connection: use null modem female-female cable.
- Plug-in screw terminal wiring: Accepts AWG #12 ~30 wires.
- Wireless transmission distance: 100M.
- Antenna cable length:1530mm.
- RS422/485 distance: up to 4000ft. (1200M)

- LED indicator: Power, Link, TX, and RX.
- Power input type: Screw terminal or DC plug.(5.5\*2.1\*12mm/500mA)
- Power consumption: 1.2 watt.
- Operating temperature: 0 to 50 .
- Storage temperature: -20 to 65 .
- Humidity: 10-90% Non-condensing.
- Dimension: 151mm X 75mm X 26mm.
- Weight: 400g.

## 2. Hardware Description

### 2-1. Panel layout

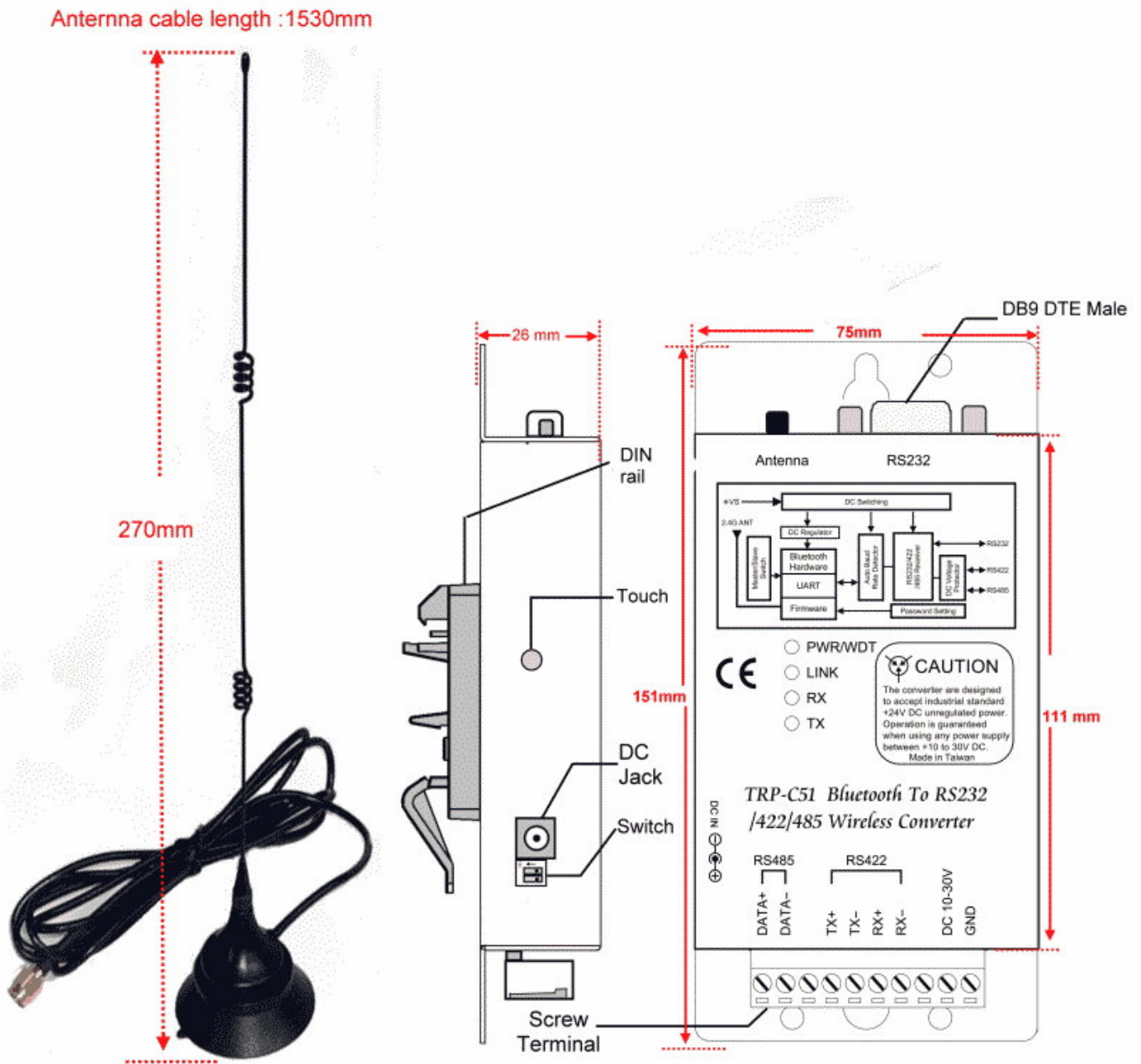

## 2-2. Block Diagram

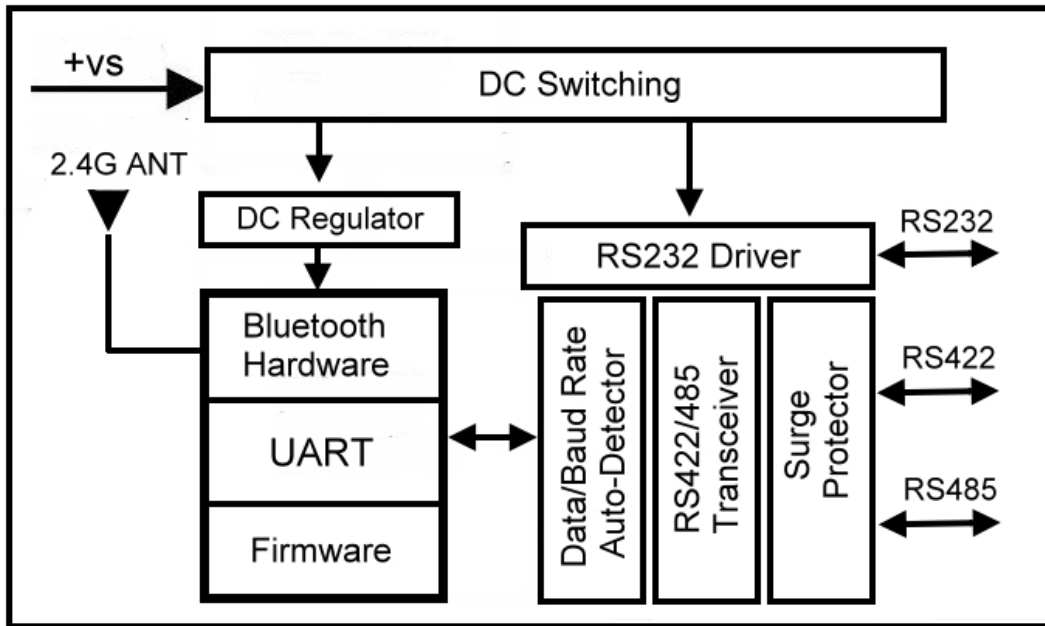

## 2-3. LED Indicator

### PWR LED:

When power is properly supplied to TRP-C51, the PWR LED will on.

### LINK LED:

TRP-C51 can be configured as Master mode or Slave mode. When TRP-C51 is in Master mode, the LINK LED definition is as below.

- A: Turn on/off in 150ms cycle – when TRP-C51 is in slave searching status.
- B: Turn on/off in 1000ms cycle – When TRP-C51 is in slave connecting status.
- C: Turn on— Master and Slave connection is successful.
- D: Blinking— If there is activity such as data transmitting or receiving.

When TRP-C51 is in Slave mode the LINK LED definition is as below.

Turn on/off in the cycle of “1000ms on/ 3000ms off” – no connection.

Turn on— When Slave and Master connection is successful.

Blinking— When there is activity such as data transmitting or receiving.

**TX LED:** RS232/422/485 data transmitting.

**RX LED:** RS232/422/485 data receiving.

## 2-4. DIP Switch

There are 2 dip switch on TRP-C51. One 2-pin dip switch is for system configuration, another is a 4-pin dip switch for extension and no function.

## 2-4-1. The 2-Pin DIP-Switch for configuration mode

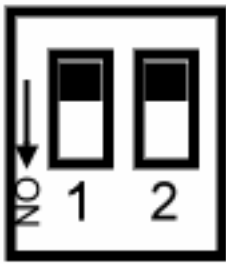

SW1,2: OFF OFF: Normal mode

SW1,2: ON ON: Configuration mode

SW1,SW2: OFF OFF -- Normal mode.

TRP-C51 can only work in normal mode. In this mode all system setting are completed.

SW1,SW2 : ON ON -- System configuration mode.

This mode is for system configuration change. When adjust the switch to ON/ON position TRP-C51 will stop all activities. User may run TRP-BT utility to change the baud rate, UART format or the other settings. After the configuration change completed, revert the switch to OFF/OFF position and reboot the system. All the system changes will be effective after the system reboot.

### 2-4 Micro Touch button

TRP-C51 micro touch button provides user with “new link” function when user want to drop existing connection and create a new connection with new device.

The Micro touch button can only work when TRP-C51 is defined as Master. When TRP-C51 is in Slave mode the button is no function.

The Micro touch button is no function, if TRP-C51 already had default “BD address”

## 3.Install TRP-C51

### 3-1. Serial Connection

The TRP-C51 is equipped with one DB-9 male connector which is configured as a DTE (data terminal equipment) device. All PC COM ports are DTE ports.

A null modem cable is required to make a connection between the PC COM port and the TRP-C51 serial port.

### 3-2. Power Connection

The TRP-C51 is equipped with a 2-pin terminal block and power jack. Power can be supplied from terminal block or external DC plug. It support wide input range from +10~+30V DC/500mA power supply. When power is correctly supplied the PWR LED will turn on and the system is ready.

If the power input from external, Please use the power plug specification. (5.5\*2.1\*12 mm).

**Warning:** User can only choose one of following 2 power sources.

- 1. External DC adapter. 2. Screw terminal DC input

Do not use both power input simultaneously.

### 3-3. RS232 wiring connection

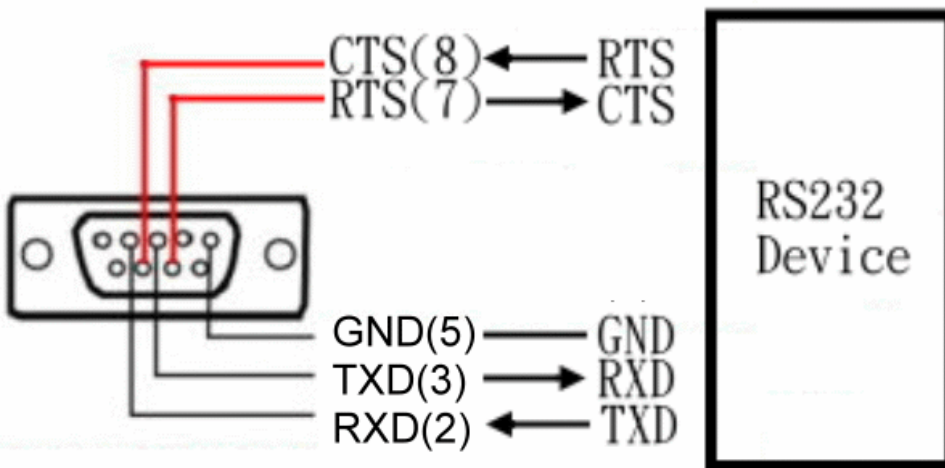

### 3-4. RS485 wiring connection

The RS485 mode supports the Transmit and Receive channels using 2-wire half-duplex operation. Refer to the pin assignment for connection as below.

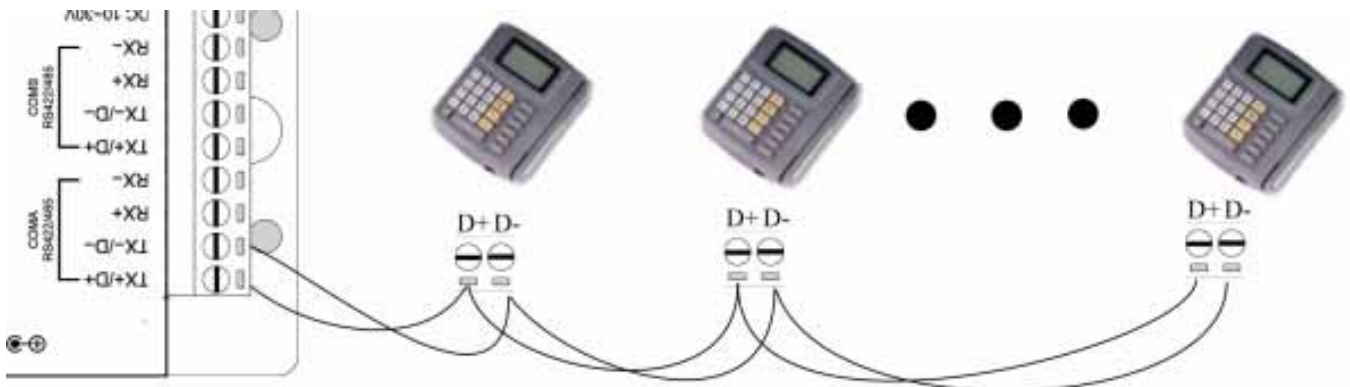

**\*The RTS/CTS must be disable if the user using the RS422/485 function.**

### 3-5. RS422 wiring connection

The RS422 mode supports 4 channels with full duplex operation for Receive and Transmit, The data lines are in differential pairs. Refer to the pin assignment for connection as below.

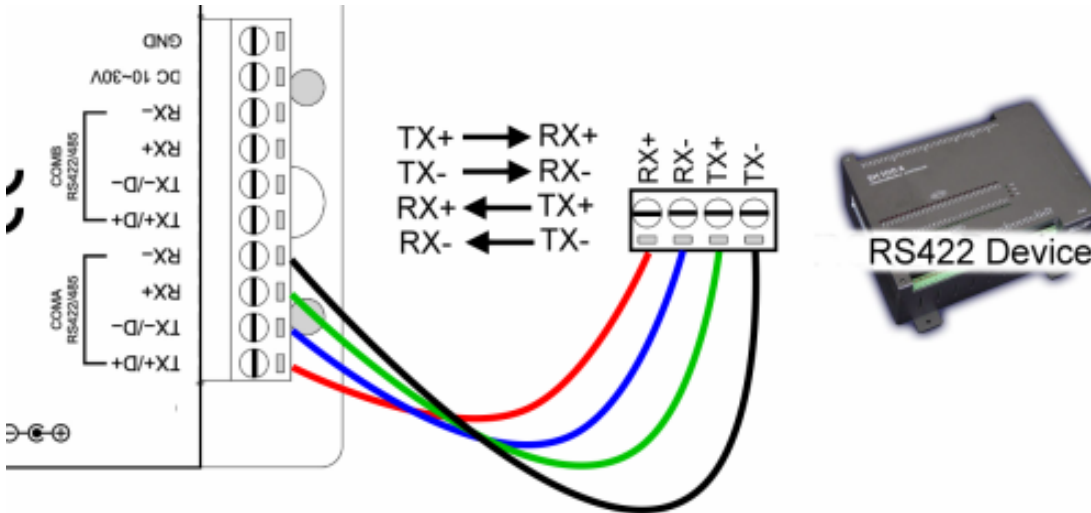

**\*The RTS/CTS must be disable if the user using the RS422/485 function.**

## 4. Getting start

### 4-1. TRP-C51 default Settings

#### Bluetooth Status

Name: TRP-C51  
 Password: 1234  
 Connection Mode: Slave  
 Device: Discoverable

#### UART Status

Baud Rate: 9600  
 Data Bit: 8  
 Parity Check: None  
 Stop Bit: 1  
 RTS/CTS Flow Control: Disable

### 4-2. Configure TRP-C51

**Step1.** Use a Null modem cable (crossover female to female cable) to make a connection between the TRP-C51 DB-9 connector and PC DB-9 connector.

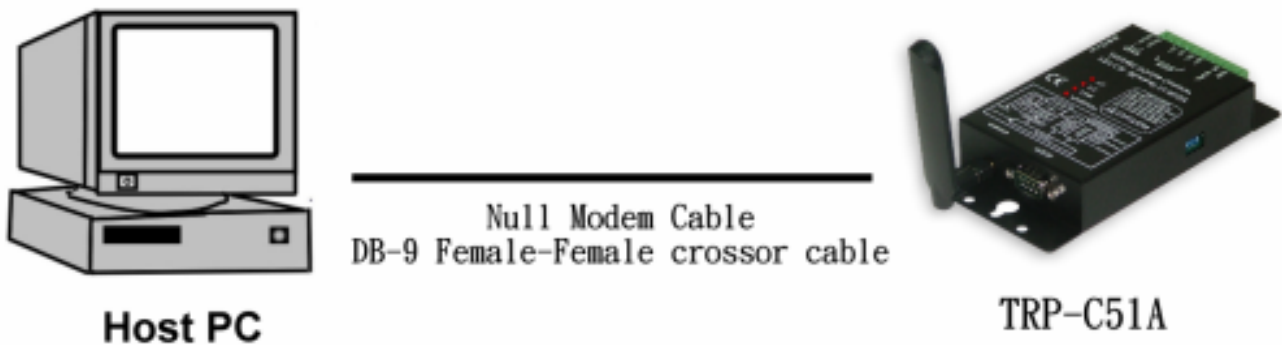

**Step.2** Run the TRP-BT Utility by window  
 User may find the TRP-BT utility in TRP-C51 support CD.

TRP-BT.EXE the configuration screen appears.

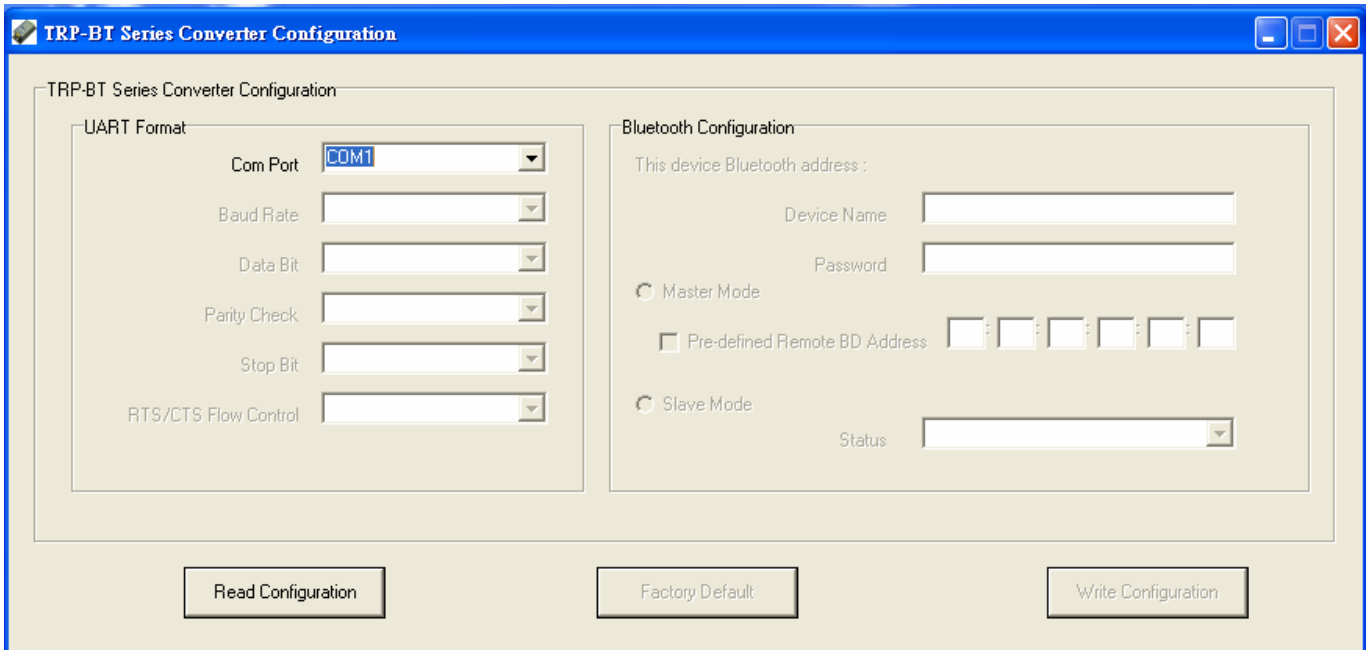

**Step.3.** Adjust 2-PIN SW to the ON, ON position (System configuration Mode) then power on TRP-C51.

**Step.4.** Select the PC RS232 COM Port for TRP-C51.

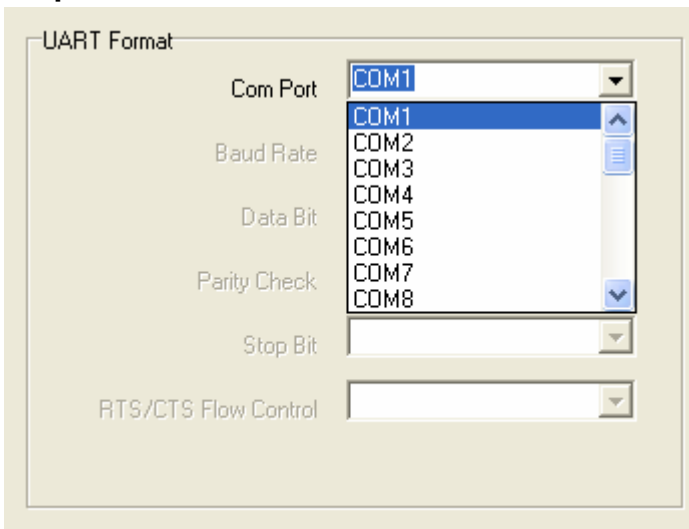

**Step.5** Click the “Read Configuration” button to read the TRP-C51 firmware configuration.



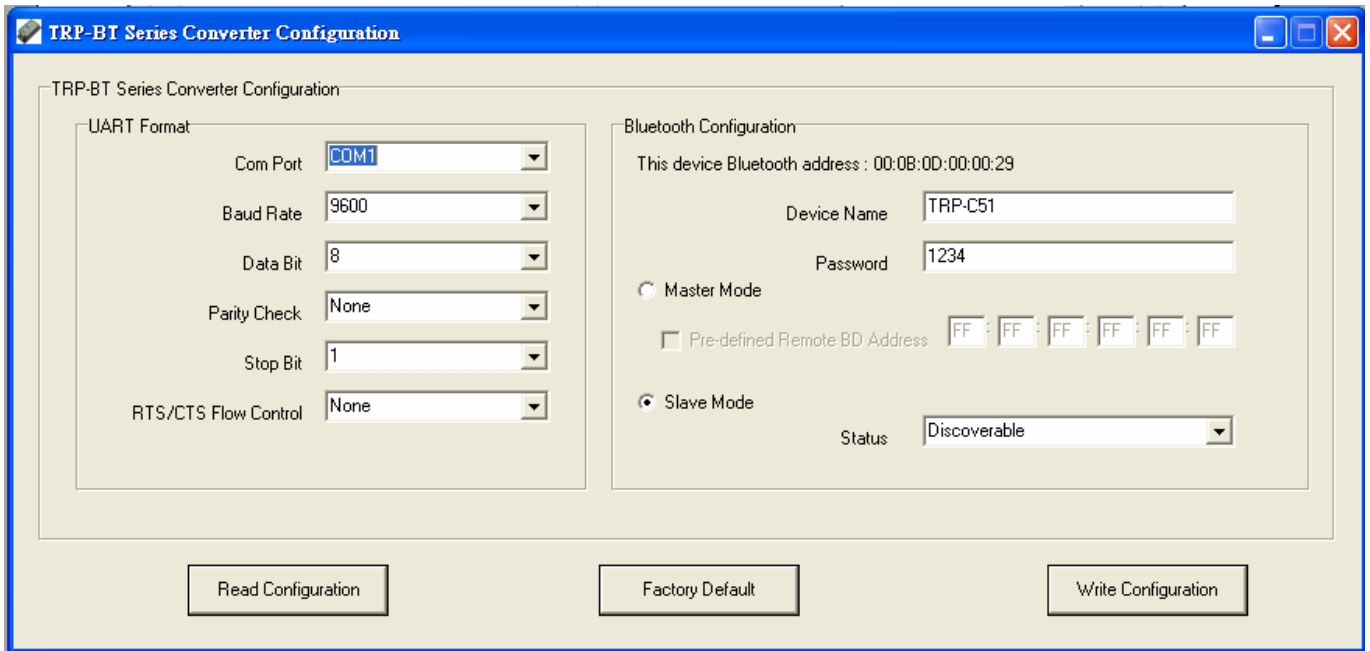

**Step.6** Select the baud rate from 1200 bps ~ 256 K bps.

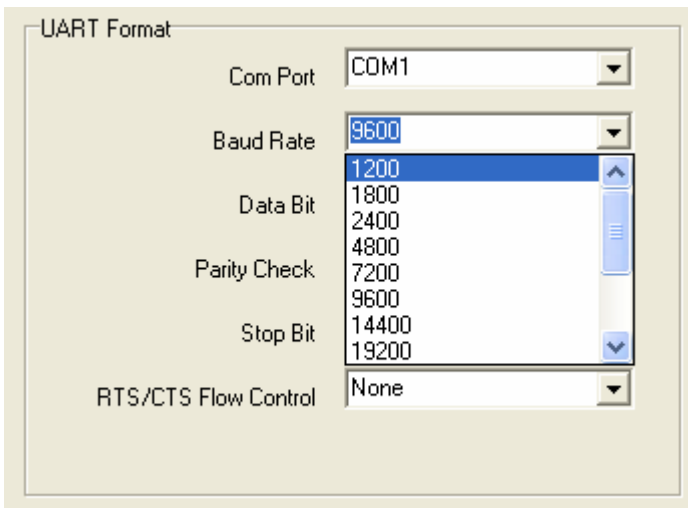

**Step.7** Select the data bit form 5~8.

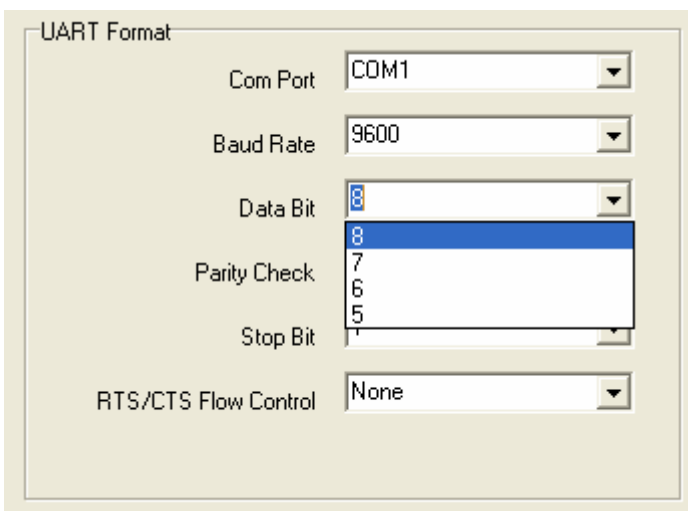

**Step 8 Select the Parity Check.**

The screenshot shows the 'UART Format' dialog box with the following settings: Com Port: COM1, Baud Rate: 9600, Data Bit: 8, Parity Check: None (dropdown menu is open showing None, Odd, Even), Stop Bit: (dropdown menu is closed), and RTS/CTS Flow Control: None. The 'None' option in the Parity Check dropdown is highlighted in blue.

**Step 9 Select the Stop Bit.**

The screenshot shows the 'UART Format' dialog box with the following settings: Com Port: COM1, Baud Rate: 9600, Data Bit: 8, Parity Check: None, Stop Bit: 1 (dropdown menu is open showing 1, 2), and RTS/CTS Flow Control: (dropdown menu is closed). The '1' option in the Stop Bit dropdown is highlighted in blue.

**Step 10 Select the RTS/CTS Flow Control.**

The screenshot shows the 'UART Format' dialog box with the following settings: Com Port: COM1, Baud Rate: 9600, Data Bit: 8, Parity Check: None, Stop Bit: 1, and RTS/CTS Flow Control: None (dropdown menu is open showing None, Enable). The 'None' option in the RTS/CTS Flow Control dropdown is highlighted in blue.

**\*It must be disable if the user using the RS422/485 function.**

**Step 11** Select the device name and password.

The screenshot shows a 'Bluetooth Configuration' window. At the top, it displays 'This device Bluetooth address : 00:0B:0D:00:00:29'. Below this, there are two text input fields: 'Device Name' containing 'TRP-C51' and 'Password' containing '1234'. There are two radio buttons: 'Master Mode' (unselected) and 'Slave Mode' (selected). Below the radio buttons, there is a checkbox for 'Pre-defined Remote BD Address' which is unchecked. To its right are six small boxes, each containing 'FF', representing a hexadecimal address. At the bottom, there is a 'Status' dropdown menu currently set to 'Discoverable'.

In TRP-C51 paired mode, it is necessary to set same name and password for both TRP-C51 (Master and Slave) .

**Step12.** Select the Master or Slave mode.

TRP-C51 can be defined as Master device, or Slave device here.

If define TRP-C51 as a Master, and input a Slave BD address, this Master of TRP-C51 will search only for the matched BD address of Slave device.

This screenshot is similar to the previous one, but with 'Master Mode' selected. The 'Pre-defined Remote BD Address' checkbox is now checked, and the six 'FF' boxes are highlighted with a dashed border, indicating they are active for input.

**5. How to use TRP-C51**

TRP-C51 support direct link mode and paired connection mode. User can use the host PC or Notebook which with integrated bluetooth interface to wirelessly connect TRP-C51, after the installation system will generate a COM Port for TRP-C51.

\*If host- PC or Notebook does not equip with Bluetooth interface, you need to add USB dongle as the connection interface. The approved USB dongle is Ergotech type ET-BD121 that is an

optional accessory for TRP-C51; however TRP-C51 is compatible with most of USB dongle in the market. User may use own USB dongle for Bluetooth interface. In the next TRP-C51 operating descriptions we use ET-BD121 as example.



**5-1. Direct link mode**

**Step1** Power on TRP-C51 and select TRP-C51 as slave.

TRP-C51 accepts + 10~30V DC/500mA power supply. When power is correctly supplied the PWR LED will start lighting, the system is up and discoverable. Use TRP-BT utility to select TRP-C51 as slave.

**Step.2** Install Bluetooth ET-BD121 USB dongle driver and utility.

User may find ET-BD121 USB dongle driver and utility it the ET-BD121 support CD. Insert the CD in the CD drive on the PC the driver CD will auto run. The following InstallShield screen appears. Press “Next > “to continue

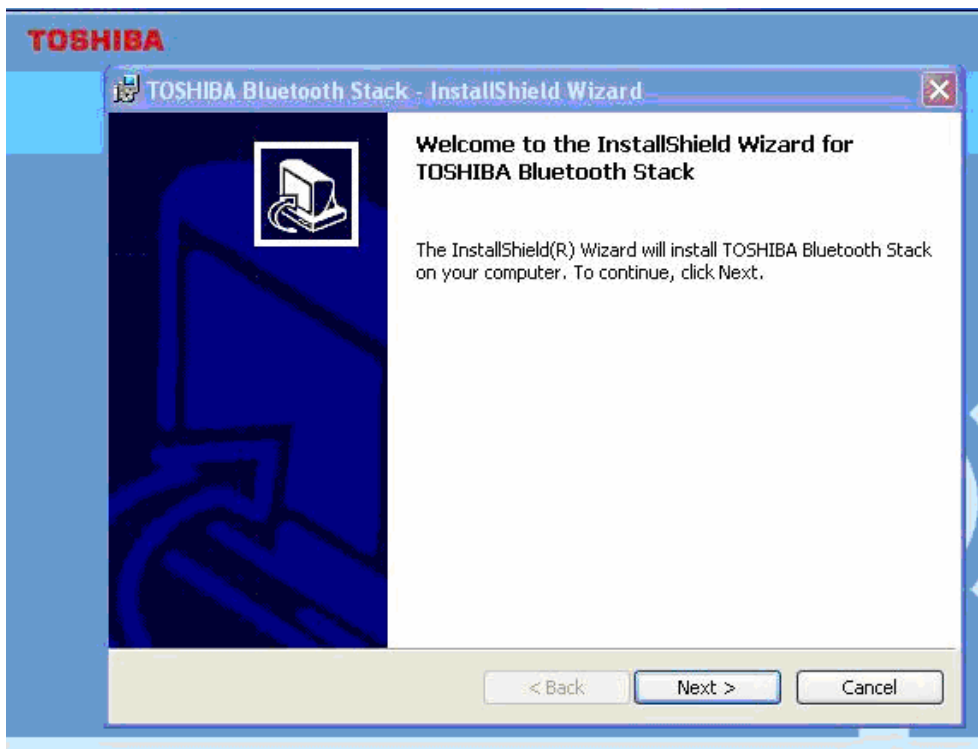

**Step3** Plug in the ET-BD121 USB dongle

The InstallShield Wizard will request user plug in ET-BD121D3 during the installation, then user must plug in ET-BD121 on the PC’s USB port. After plug in ET-BD121, press “Next” to start

installation. The whole process will take few minutes, when installation completed press “Finish” to end the process.

#### Step4 Bluetooth setting

After ET-BD121 driver installed, back to the Windows screen and Click Start – Program file – Bluetooth – Bluetooth setting. The Bluetooth settings screen appears.



**Step5** Click on “New connection “icon into the Add New Connection Wizard, the USB dongle start to search all discoverable TRP-C51 units. Suppose just only 1 TRP-C51 unit need to be installed, we can see there is only one Bluetooth device been searched with the device name TRP-C51. Click “Next>” to continue.



**Step6** Select installation mode.

Select Express Mode: The COM port is assigned by system.

Custom Mode: Allow user freely to assign the COM Port to TRP-C51

Confirm with "Next>"

In the next description we select "Custom mode" for explanation.

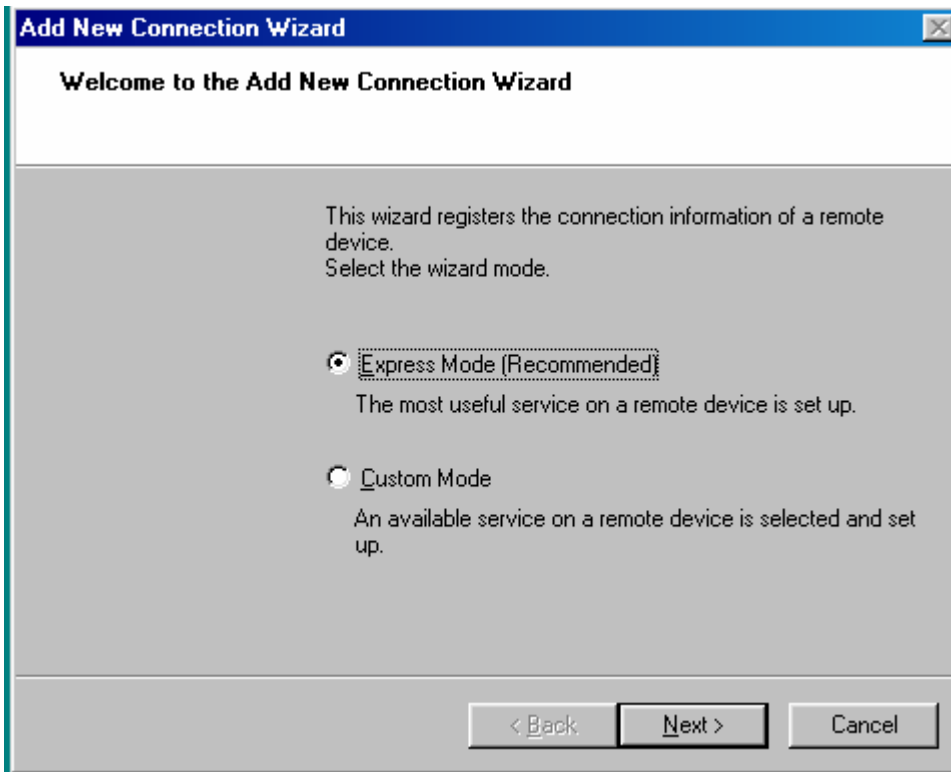

**Step7:** Assign a appropriate COM port for TRP-C51 and confirm with "Next>".



“Auto Connect” means TRP-C51 will automatically connect when encounters unexpected disconnection.” User may choose the function enable or disable.

**Step8:** Select the installed TRP-C51 icon and click mouse right button to check or change options. User may rename or delete the TRP-C51 here.

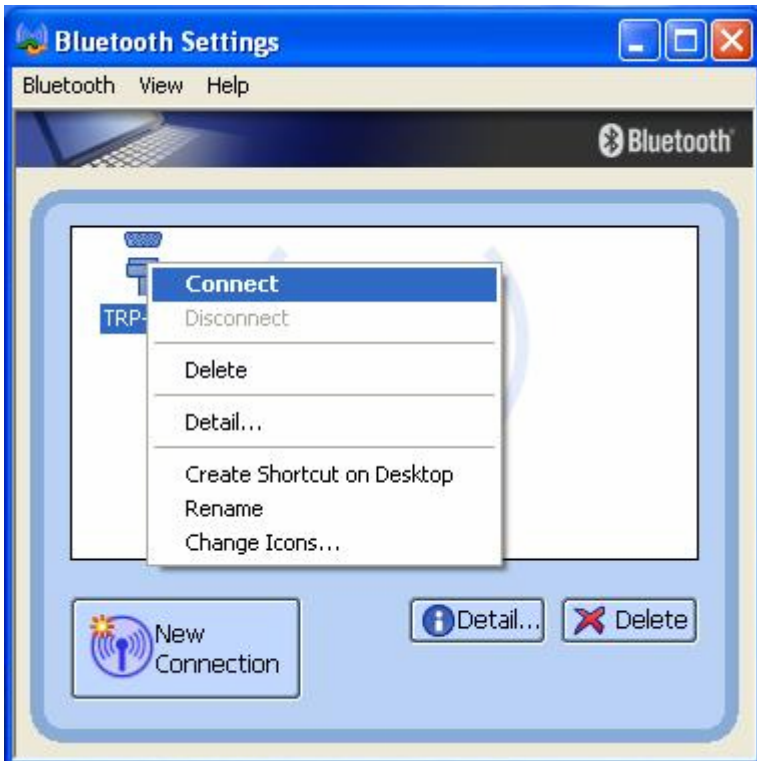

Select “Connect” option you are requested a Bluetooth passkey. Please Input TRP-C51 password which must be same as the setting by TRP-BT utility, press OK, TRP-C51 will go into searching mode, the LINK LED start to fast blinking.

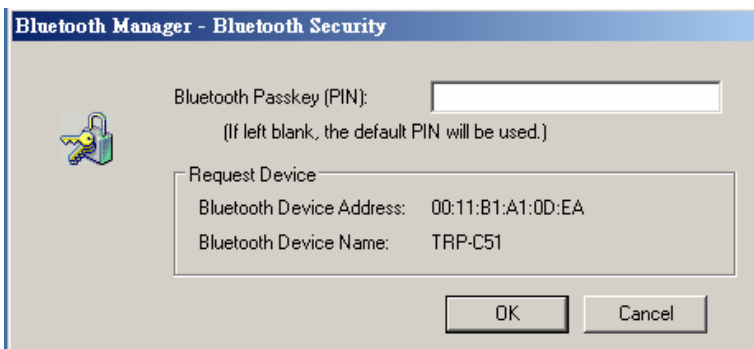

**Step9:** When TRP-C51 is successfully connected user may see the next screen, the LINK LED stop fast blinking and turn to lighting. TRP-C51 is available to data communication or control. You also may find TRP-C51 has already been added in system device manager.

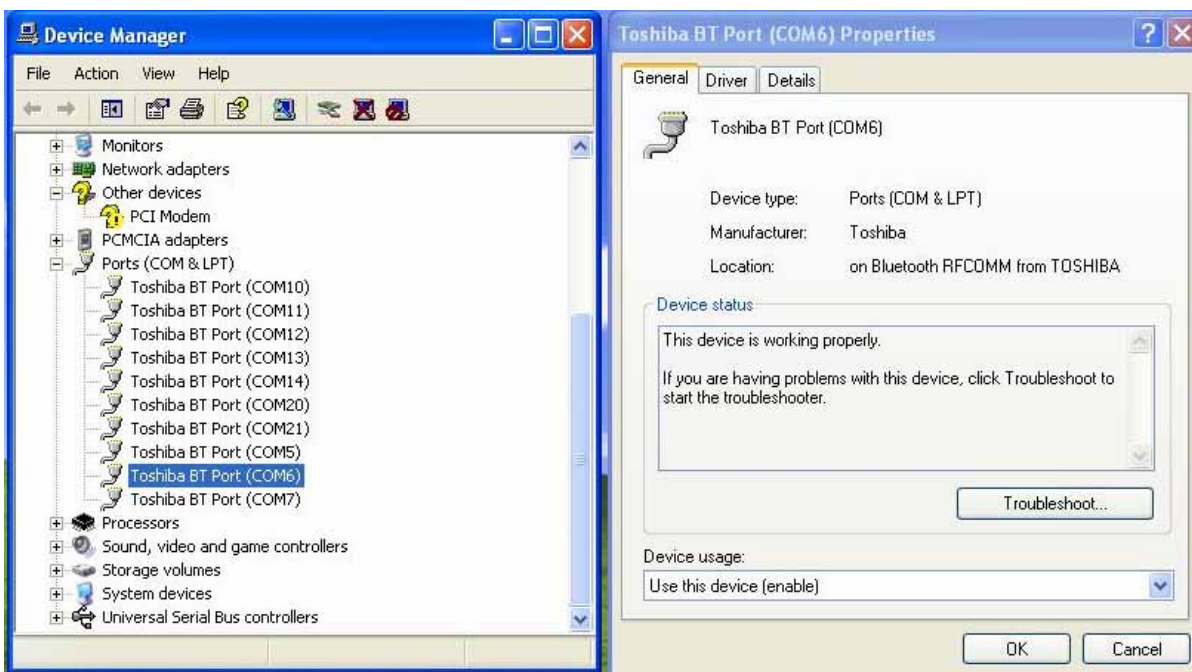

User may back to the Windows screen and Click Start – Program file – Bluetooth – Bluetooth setting to start the second TRP-C51 installation. The number of TRP-C51 that a Host system may install is depended on the COM Port number that the system or OS can offer.

## 5-2. Paired mode

TRP-C51 paired mode allows user to make a wireless connection between 2 RS232/422/485 devices or PLC (Programmable Logic Controller) without hardware or software changes. In this mode the data line signal and data format can be auto detected and converted between each other. The communicating range can up to 100M.



### 4-3. How to set up TRP-C51 paired connection mode

**Step.1:** Use TRP-BT utility to set one TRP-C51 as master, and another TRP-C51 as slave. Both TRP-C51 devices name and password must be same.

**Step.2:** Put both TRP-C51 in system connection and power on, the both TRP-C51 LINK LED start to blinking, that means they are in searching each other status.

**Step.3:** When both units LINK LED become constant lighting, both TRPC51 had been successfully connected each other, the system is ready and workable.

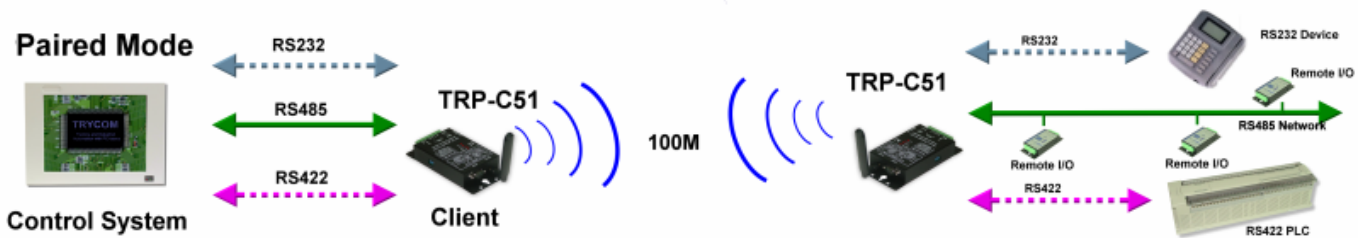

## 6. How to test TRP-C51

The demo and test utility, these utilities may help user to demo and test TRP-C51 fast and easily. User may find the utilities in support CD. The testing utility includes

RS422 test utility

test422.exe for DOS

DEMO.exe for Windows

and RS485 utility

test485.exe for DOS

TRPCOM for Windows.

### 6-1.RS232 Loop Back Test

RS232 loop back test wiring connection.

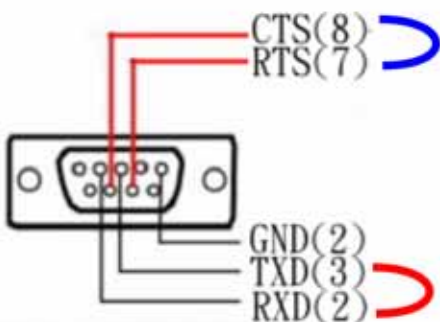

## 6-2.RS422 Loop Back Test

RS422 loop back test wiring connection.

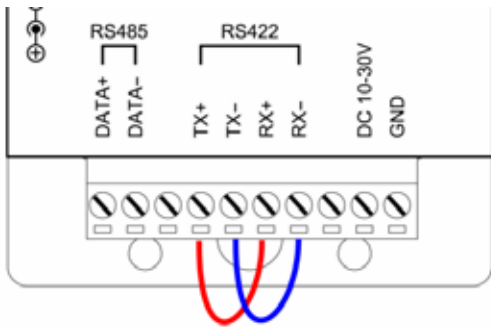

## 6-3.Loop Back Test Software

**Step1.**Run the “DEMO.EXE” utility (See the Figure 5).

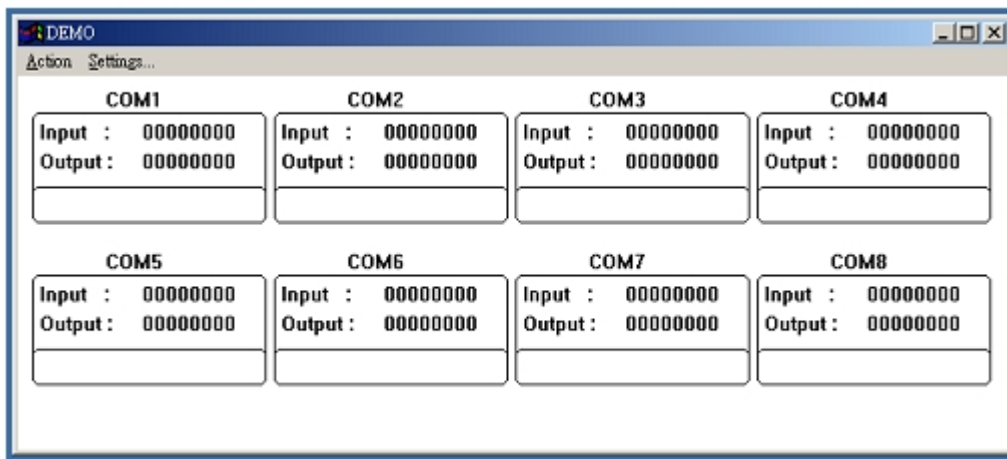

Fig.5

**Step2.**Click the “Setting” to set the RS422 loop counter (See the Figure 6); your system will detect the COM3.

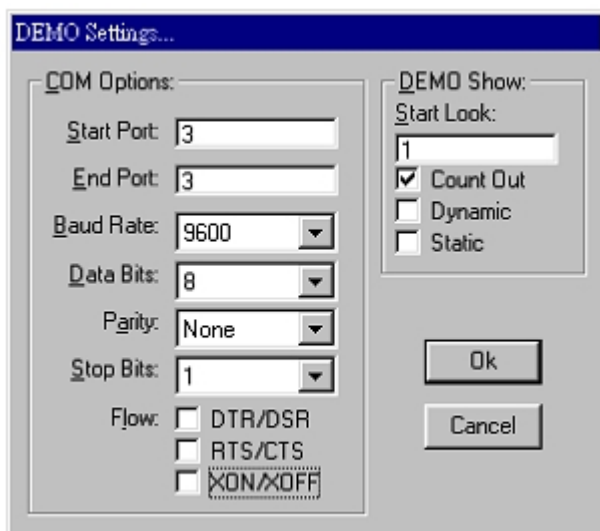

Fig.6

\* Please note: “COM3” is an example of COM port number; user may set a different COM port number after the installation. The actual COM port number is assigned by user.

**Step3.**Click the “Setting” to set the RS232 loop counter (See the Figure 7); your system will detect COM3.

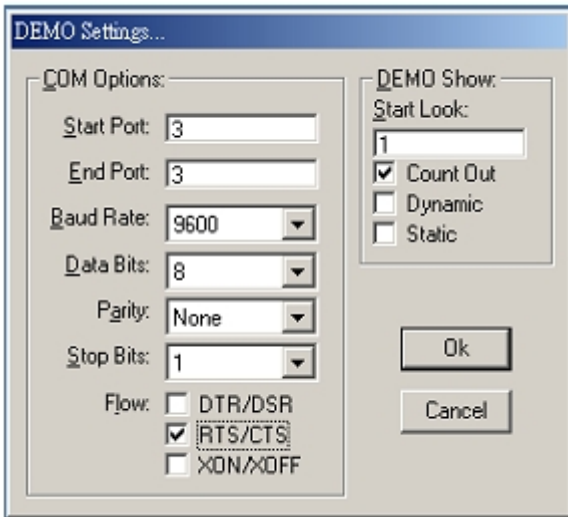

Fig.7

**Step4.** Click the “OK” the utility will show the input and output status of RS232 (See the Figure 8).

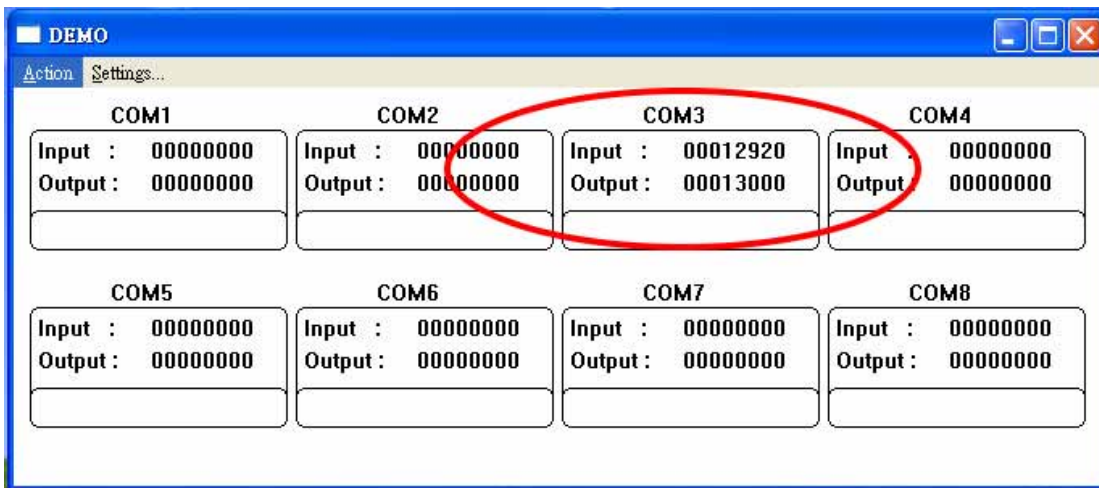

Fig.8

#### 6-4. RS485 Test

Refer to the RS485 wire connection. User may also directly link TRP-C51 to Remote IO modules, the wiring connection is as below.



**Step1.** Install TRPCOM utility.

TRPCOM is a test utility which may help user to test TRP-C51 with RS485 device easily. User may find the utility in the TRP-C51 support disk. Double click “Setup.exe”, the install Wizard will guide you to complete the installation.

**Step2.** Configure COM port and baud rate, after configuration press “OK” to the next screen.

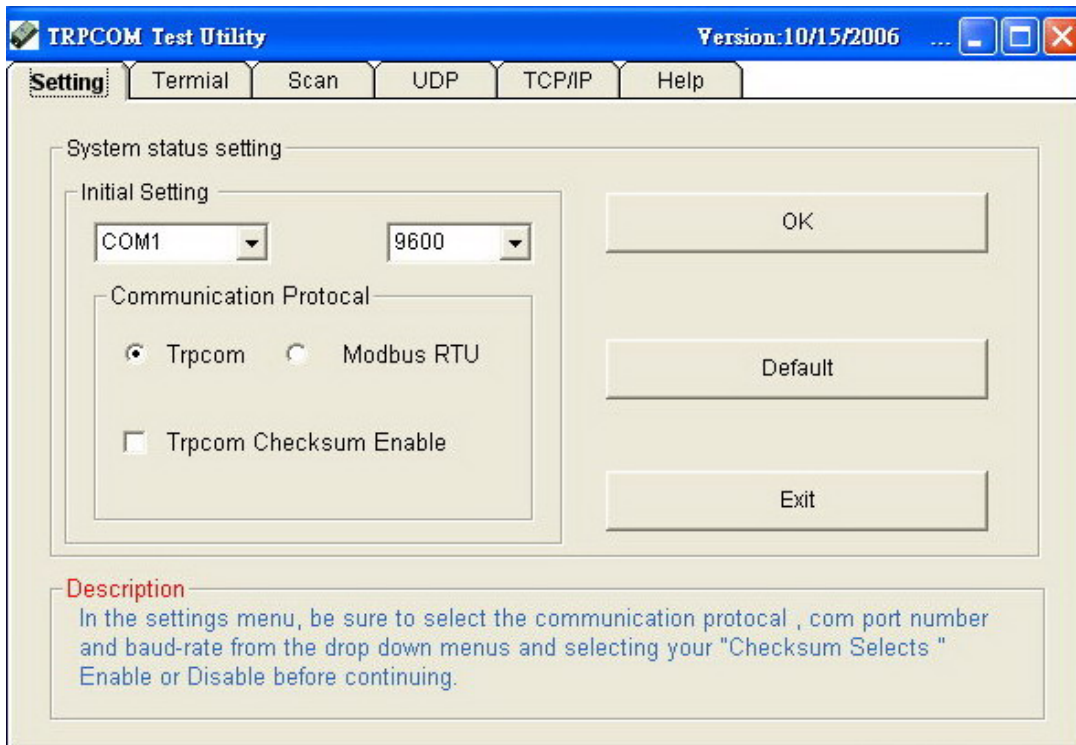

**Step3.** Send command "\$01M" and press "Send".

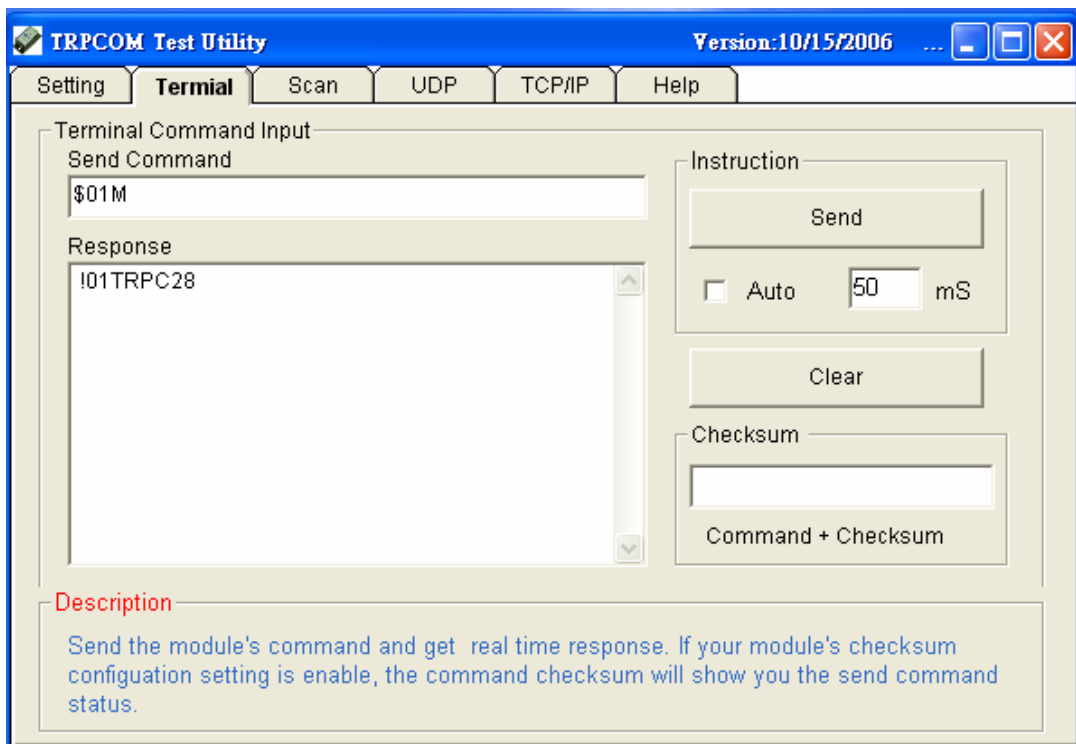

**Step4.** Data response received.  
Test complete.